

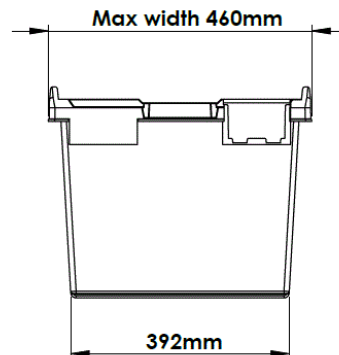

Versatote™, the most flexible solution for storing and transporting your products

Attached Lid Container – 80L LC3

- Manufactured from polypropylene for strength and endurance
- Stack when full, nest when empty for cost effective transportation
- Interference free lid movement, ideal for automatic closure devices
- Print options available
- Tote identification via barcodes optional
- Optional colours available subject to volume
- Auto banding-strap slots
- Tamper evident seal locations both ends

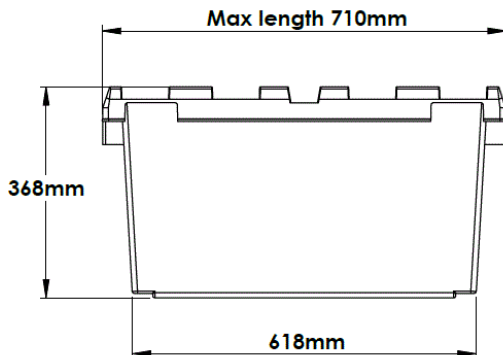
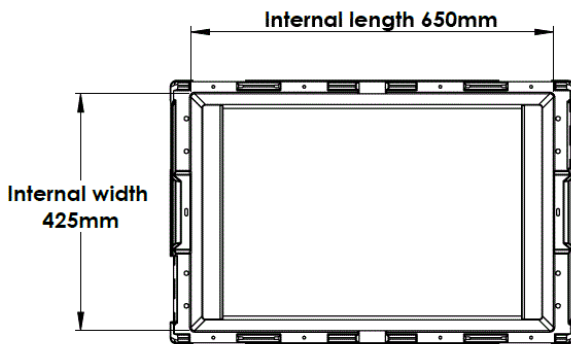

Casting Support Systems Ltd
Kemmings Close, Long Road,
Paignton, Devon, TQ4 7TW

t. +44 (0)1803 520 495
e. sales@versatote.com
w. www.versatote.com

Technical data

Product reference.	LC3
External dimensions mm.	710 x 460 x 368
Weight Kg.	4.30